

THE MAGAZINE FOR POWER TRANSMISSION

PERSPECTIVES

#1 | 2012

METROPOLITAN REGION DELHI

MAKING WAY FOR PUBLIC TRANSPORT

MINING
POWER IN THE DARK

VOITH AQUATARDER SWR
TEST RIDE

SÃO PAULO
GERMAN HOTSPOT WITH POTENTIAL



A colorful mix of traditional and modern transport gets people on the move in India's mega-metropolis Delhi.

Publisher:
Voith Turbo GmbH & Co. KG
Alexanderstraße 2
89522 Heidenheim, Germany

Responsible:
Marion Jooss

Editorial Head Office:
Maria Arbogast

Telephone: +49 7321 37-2802
Fax: +49 7321 37-7110
Maria.Arbogast@voith.com
www.voith.com

Text, Layout and Graphics:
KircherBurkhardt Stuttgart GmbH

Printing:
C. Maurer Druck und Verlag GmbH & Co. KG

Photos:
All photographs by Voith Turbo unless otherwise stated.

Copyright:
No part of this publication may be reproduced or processed in any other form without the express authorization of the publisher. It is also not permitted to use the contents of this publication or parts thereof in whatever format in other publications without the approval of the publisher.

PR 0021 © 1/2012

Would you like to learn more about Voith?
www.voith.com

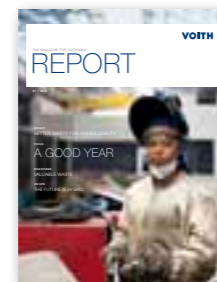

REPORT
The Magazine for Voithians

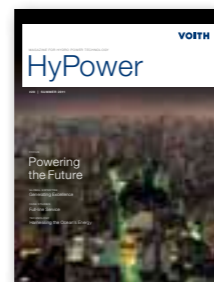

HYPOWER
The Magazine for Hydropower Technology



TWOGETHER
The Magazine for Paper Technology

HIGH-END TECHNOLOGY FROM VOITH

PARTNER FOR MEGATRENDS

Dear Readers, mobility, urbanization, resource protection and renewable energies are the most pressing global megatrends for the next few decades. With our products and services, we are responding to issues that affect people worldwide. For example with our drive solutions for rail and road vehicles as well as ships, which ensure that millions of people all over the world can travel eco-friendly and safely, and that goods reach their destination efficiently.

This also applies to the growth region India, where Voith has been active for more than 100 years with a variety of projects. This year, our Group Division Voith Turbo is celebrating the 25th anniversary of its location in Hyderabad.

ing rapidly, and the traffic reaches its limits day after day. Read how our products contribute to improving the situation.

Voith technologies are also in demand in another growth region, i.e. Brazil, which is currently exploiting new oil fields and working on the improvement of its infrastructure for the Football World Cup in 2014 and the Olympic Games 2016. Every day, three million people are using the São Paulo metro fitted with technology from Voith. And Voith will deliver 60 Vorecon gear units during the initial stage of the new oil fields.

You can also learn why it pays off to change to the Aquatarder – for the environment, but also for safety and eco-friendly operation – and why this innovative Voith product has been awarded the European Transport Sustainability Prize.

So let me take you on a literary journey through the fascinating world of Voith.



The main theme of this issue of Perspectives is the Indian metropolis Delhi. This city region is grow-

Yours sincerely,

DR. HUBERT LIENHARD
President and CEO of the Management Board of Voith GmbH,
Chairman of the Management Board of Voith Turbo.



PAGE 10



PAGE 24



PAGE 39



PAGE 48

EDITION
1/2012

DESTINATION
DELHI

PANORAMA
VOITH TURBO NEWS

EXPEDITION
RETARDER

PERSPECTIVES
MULTIMEDIA

PERSPECTIVES
The Magazine for Power Transmission

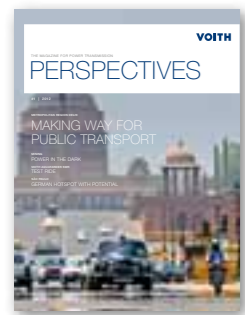

10 MAKING WAY FOR PUBLIC TRANSPORT

Driving in Delhi is not for those of a nervous disposition. The horn replaces any traffic rules. A trip through the metropolis that is growing so fast that the infrastructure can't keep up.

22 WORTH KNOWING

Per-capita income, climate, history – facts and figures of the business region Delhi and Voith Turbo in India.

23 COUNTLESS OPPORTUNITIES

For the future, Debashis Basu, Managing Director of Voith Turbo in India, banks primarily on increased local production.

24 GETTING CLOSER

Voith presents itself on site during the German-Indian Year.

28 INDUSTRY

30 MARINE

32 RAIL

36 ROAD

**Different dimensions:
The world's largest
Voith Inline Thruster.**



FEATURES

- 06 TAKE-OFF
- 26 HISTORY
- 48 SIGHTSEEING
- 51 WORLDWIDE

39 TEST RIDE

The development of modern truck braking systems started on the rails. Today, Voith Aquatarders set new standards.

45 STRONG FACTS

Modern retarders increase safety and cut down on fuel consumption.

46 "FASTER ON THE ROAD"

In an interview, the expert Holger Günther talks about practical experiences with the continuous brake. His verdict: "Once with retarder, always with retarder."

... AND THIS IS HOW IT WORKS

PERSPECTIVES also provides a selection of multimedia content to be explored through little squares on some of the pages – so-called QR codes. With a smartphone and the appropriate app, beautiful photographs turn into moving images. Follow the instructions and try it out.

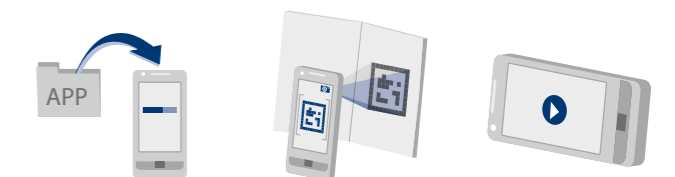

1 On your chosen platform, please select a suitable app (QR Reader) and load it to your smartphone (there are free reader apps, for example 1-nigma).

2 Open the application on your smartphone and move the camera across the QR code in the magazine. Some mobile phone cameras still have no macro function. The picture might therefore be a little blurred. In this case, scan the code from a distance – this often helps.

3 Once the QR code has been identified, your smartphone will open the connection to the respective multimedia contents. Get going! But please note: You should have a flat rate, otherwise, videos might result in high charges.

ARMORED-FACE CONVEYOR

POWER IN THE DARK

This is a place where most people would rather not go, unless they really had to. We are visiting a mine, hundreds of meters below the surface. It is hot, sticky and the artificial light is diffused by the coal dust. Our ears are booming with the noise of the machines. Down here, coal is extracted. Mighty armored-face conveyors tear through the coal seam. The motors never sleep; standstill means loss of earnings. All sections of the conveyor and the drive have to work reliably despite the extreme conditions.

Another conveyor has just started and the shearer with its many chisels begins to rip coal from the longwall, accompanied by thunderous noise. Lumps of all sizes incessantly crash on the conveyor, which moves the "harvest" away from the seam. Again and again, chunks of coal get dumped on the chain, but the plant never blocks. Yet blockages can occur, for example if the conveyor is overloaded. In such a case, the plant stops and then restarts. This calls for enormous and precisely dosed torques to ensure that the chains are not overstrained. The Voith CPC 1 600 coupling limits and safely transmits maximum allowable torques from motor to drive system. >

Lots of underground work:
An armored-face conveyor tears coal off the seam – relentlessly.

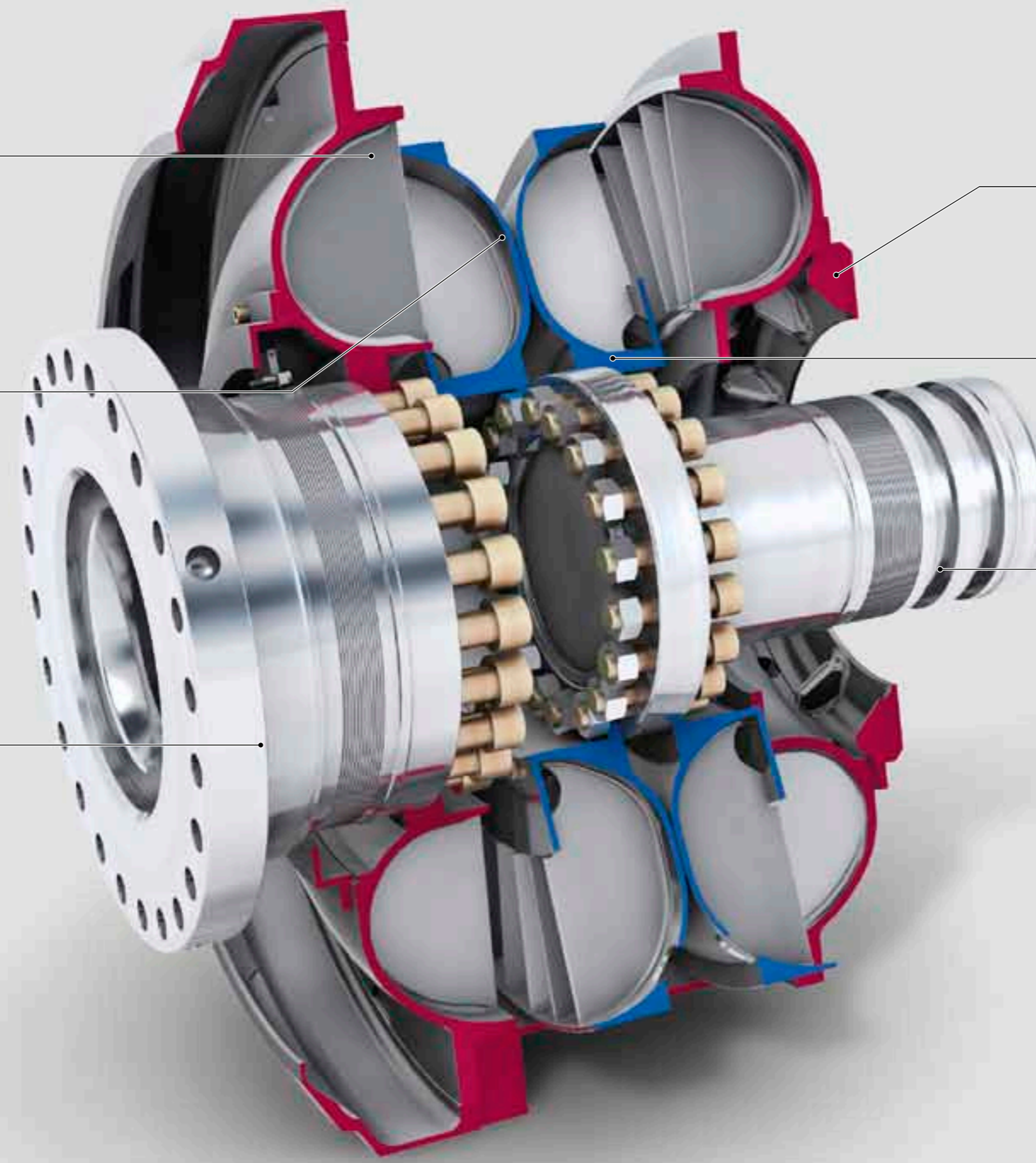

XL profile

A quantum leap in hydrodynamics: Newly developed, highly efficient rotor geometries with nearly identical outer dimensions transmit twice the output – with further optimized starting and overload behavior.

Double circuit

Two couplings in one: Compact unit with twice the output but with the same diameter. The hydraulic axial thrust is largely mutually compensated.

Motor start-up

The multi-motor drives run-up consecutively while the coupling is empty. As a result, robust squirrel-cage motors can be used without having to overdimension the grid for starting current.

Water-fill operation

An eco-friendly and sustainable solution. It provides highly efficient cooling during operation, as hot water is instantly replaced by cold water.

Maximum torque

Precise settings and exact repeatability across the diameter of the throttle plate. Maximum torque is always available for start-ups and overloads during operation.

Mass separation

The mass inertia of the high-voltage motor does not affect the transmission side. Rapidly occurring blockages and jolts are dampened more effectively than with rigidly coupled motors.

▷ “I don’t know any armored-face conveyor drive system in the world that comes even close to the start-up capacity and maximum chain protection of our fill-controlled water couplings. We launched this technology in the market as early as 1990, with an output of 314 kilowatt. Over the years, this rating has been continuously increased, until we arrived at 1 000 kilowatt in 2005. Due to the introduction of our newly developed XL technology, we reached another milestone: Doubling the hydrodynamic output, but retaining the original size. In this way we were able to set new standards for armored-face conveyors with a nominal output of 1 600 kilowatt.” //



BERNHARD SCHUST

The Sales Manager Industry has been with Voith since 1979. The 58-year-old graduate engineer has more than 30 years of experience with drive technology for underground mines, and he looks after the Voith equipment in mines in overseas continents like Asia, Australia and North America.

MOBILITY IN INDIA'S CAPITAL

MAKING WAY FOR PUBLIC TRANSPORT

India's metropolis grows and grows – and so does the traffic. In their search for possible solutions, the city leaders focus more and more on public transport. Anybody who has spent a day in the streets of Delhi longs for the modern, fast and, most of all, reliable metro.

TEXT: CHRISTINE MÖLLHOFF

Modern buildings in Delhi: Okhla Railway Station and the Lotus Temple are symbols of modern India.

A mix of cars, motor-bikes, rickshaws and buses characterizes the Delhi cityscape.





The traffic is often static, but life on the roadsides in Delhi is definitely vibrating.

PHOTO: ISHAN TANKHA

Viewed from above, the situation does not seem to be too bad. It is early in the morning. From his hotel window, the European visitor to the Indian capital looks at a junction. While the traffic is already quite heavy so shortly after dawn, the stream of buses, trucks, bicycles, small vehicles, handcarts and mopeds appears to run in an orderly fashion. This is hardly surprising: Pulling in and out is difficult, because most of the time, the commuters are gridlocked. Not really so different from the rush-hour traffic in other large cities. Why have Indian experts warned that the many culture shocks on the subcontinent also include highly erratic traffic conditions?

And then the traffic lights turn green – and the previously fairly uniform flow of vehicle begins to dance. Suddenly, the vehicles criss-cross like goldfish in a bowl, turn-off lanes are a matter of interpretation, nobody sticks to any rules. Everybody just wants to get ahead, the choreography is spontaneous and is redesigned every few seconds. Driving in the Indian capital Delhi is not for people with a nervous disposition, the horn replaces any traffic regulations. The spectator high above might even be quite amused, thinking that this is what the legendary “creative chaos” must look like. Then the traffic lights change again – and the scene freezes once more. This occurs virtually every few minutes, and the viewer soon begins to realize the huge contrast: India, one of the oldest democracies in Asia, is leaping forward and conquers the data highways of the world at breathtaking speed. But in order to get the nation really rolling, sustainable traffic concepts are required, which can keep up with the rampant growth and prevent frequent gridlocks. And ideally, and most credibly, they should be in-

troduced in the capital, where mobility is still dominated by mopeds, often carrying entire families through the traffic chaos. The latter is occasionally heightened by a cow peacefully trotting along in the middle of the road.

Vijay Singh has come to terms with the masses crowding the roads to the best of his abilities. Stoically, he steers his way through the pandemonium. He has been a taxi driver in Delhi for 33 years. People in a hurry are lost here. Singh spends more time sitting in traffic jams than actually driving. Like so many others in the capital he groans under the daily deluge moving into the center in the morning and back out in the evening. Many Delhiites spend at least two hours or more on the roads, and if they want to go to the cinema or a restaurant, they have to fight their way through the traffic. Always on the go, many long for progress. Yet the 53-year-old Singh still loves his job and also his old-fashioned Ambassador limousine oozing nostalgic charm.

But anybody who wants to get to his destination fast, safely and most of all reliably, has long discovered the metro – the Delhi Mass Rapid Transit System (DMRTS). What is taken for granted in other mega-cities, is still being gazed at in Delhi, sometimes in wonder. The metro is indeed a highly acclaimed showpiece. The advantages of this rail system were discovered fairly late, the first cut of the spade took place in October 1998. But by now line expansions are in full swing; for the traffic planners the extension of the network is the effective answer to easing the rush-hour worries. On December 24, 2002, the first route was opened by the then Prime Minister Atal Behari Vajpayee, by 2016 the partly underground network is to >

TRAFFIC – A DAILY ADVENTURE

Driving a car in Delhi is not for those with a nervous disposition – the horn replaces all traffic regulations.



Right of way in Delhi: From high above, the traffic looks a lot tidier than it actually is.

▷ cover 295 kilometers. Following an extension for the Commonwealth Games in 2010, it already measures 181.8 kilometers. So far, Voith has delivered nearly 1 000 final drives for the trains of the operator Delhi Metro Railway Co.

The city administration, the operator and the inhabitants are convinced by the concept. “Whenever I have to get somewhere really quickly, I can rely on the metro – and expect that I will arrive on time,” says student Kanupriya, “until recently, it was virtually impossible to plan anything in this city.” Delhi is indeed bursting at the seams. Only 20 years ago, 9.4 million people lived in the metropolis. Today, with just under 17 million, the figure has nearly doubled. And every year, hundreds of thousands of people from the surrounding rural areas are crowding into

the city and trying to find their luck. Most of the time they end up in the suburbs and become commuters. The metro also has a good image because it conveys the flair of the big wide world in emerging India. “It’s like in New York,” says Kanupriya, although she has never been there. The trains run every three to four-and-a-half minutes.

The rapid growth presents huge challenges to the politicians in general. The urban infrastructure has not been designed for such an onrush. In addition, the capital is situated in a seismic zone, making the construction of skyscrapers like in Dubai or Bangkok impossible. Settlements are spreading out by surface area, which worsens the traffic crisis even more. It is a permanent race, especially outside the tracks. While new roads and elevated highways are being built nonstop in and around ▷

Facts on India

Inhabitants
1.2 billion (world ranking 2)

Area
3.3 million km² (world ranking 7)

Population density
365 inhabitants per km²
(world ranking 19)



Metropolitan Regions Worldwide

Inhabitants in 2010 and prognosis for 2025 in million

City (Country)	2010 (million)	2025 (million)
Tokyo (Japan)	36.7	37.1
Delhi (India)	22.2	28.6
São Paulo (Brazil)	20.3	21.7
Mumbai (India)	20.0	25.8
Mexico City (Mexico)	19.5	20.7
New York (USA)	19.4	20.6
Shanghai (China)	16.6	20.0
Kolkata (India)	15.6	20.1

SOURCE: UNITED NATIONS

Population of India

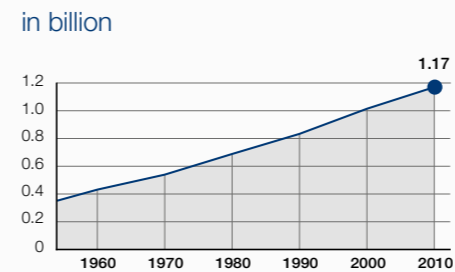

Population of Delhi

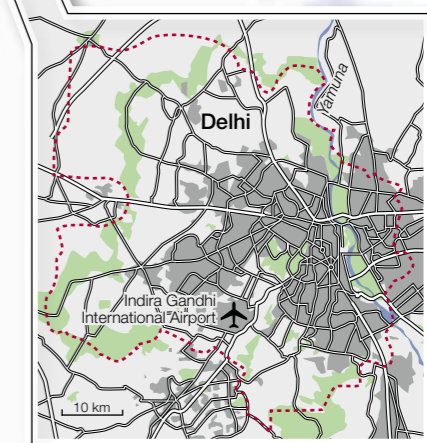
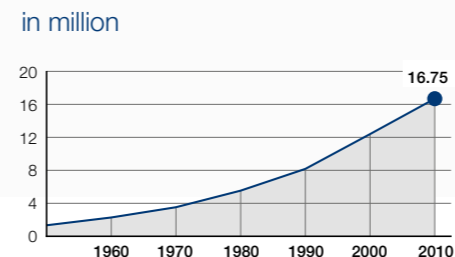

Facts on Delhi

Inhabitants
16.75 million

Area
491 km²

Population density
22 419 inhabitants per km²



Please enter: The metro is one of the most important transport systems in Delhi

A large proportion of the working day is spent waiting: Taxi driver Singh has learned to be patient in his job.

▷ Delhi, they are congested in no time. Not really surprising, because 5.5 million cars are registered in the city region; across the entire catchment area, the figure even reaches 11.2 million. And every day, another 700 to 1000 cars are added to the roads. In order to master the ensuing smog, Delhi began at the turn of the millennium to enforce a conversion to gas for all auto-rickshaws, taxis and buses. Santosh Kodukula knows how desperately the air quality needs to be improved. The 31-year-old cycles to work. Something that otherwise only

the poorest people do – or crazy westerners. But Santosh is neither poor nor suicidal. He is an urban traffic expert and a passionate cyclist. He also rides against a tide of prejudices: “People think bikes are not fit for the road, there is no respect for cyclists.” The development of the metro can be regarded as an example for the overall development of the Indian rail market – which has grown enormously in recent years. Among industrial experts, the expansion in Delhi is seen as a starting signal for further metro projects in

India. Since October 2011 Bengaluru, too, has its own metro network; in Mumbai, the first line is to be completed still in 2012, and in Hyderabad and Chennai construction work is well underway.

At present, the metro in Delhi has 138 stations. “Next stop: Central Secretariat,” sounds a recorded announcement, first in Hindi and then in English. Most metro users are dressed more fashionably and smartly than the bus passengers. Many wear jeans and sweaters, others sport the salwar kameez, a tunic with trousers, which is regarded as the classic outfit for the modern Indian woman. Prior to the introduction of the metro, buses were the only mass transport medium in the city. Only 20 years ago, they were the undisputed number one, the uncrowned kings of the road,

and they took up over 60 percent of the public transport in Delhi. At the time, India was economically isolated, there were three brands of cars and only the upper ten thousand were able to buy their own vehicle. People depended on buses. But then the country slowly opened its doors at the end of the nineties, the economy began to rally and cars and mopeds became affordable for more and more people. The share of buses in overall transport tumbled to about 40 percent, while the number of cars, mopeds and motorbikes rose steeply to 35 percent.

But despite this strong tendency towards individual traffic, things are about to change again. The city leaders have begun to modernize the bus fleet. The ancient monsters are gradually being scrapped and replaced ▷

A TOUCH OF NEW YORK IN DELHI

The metro enjoys a positive image, not least because it gives the city a truly metropolitan flair.

TRAFFIC MADNESS ALL YEAR ROUND

URBAN BRAKE DANCE

Heavy traffic and immense heat: A bus ride in Delhi soon reveals the demands made on technical systems. But DIWA transmissions from Voith help to make start-ups go as smoothly as possible.

A typical day on Delhi's roads: accelerate, brake, accelerate, roll for a few seconds, and hit the brakes again. A rhythm to which everybody has to dance. And every day it seems to get worse, as the traffic increases at an unstoppable rate. Delhi is growing at breathtaking speed. But despite a massive construction program, the roads to the satellite towns can't cope with this rapid progress. Many Indians try to move on by honking their way through the traffic, making Delhi one of the noisiest cities in the world. An attempt to introduce a “honk-free” day failed.

It is therefore a blessing that 46 percent of all trips are meanwhile carried out on public transport systems. Many people

take the bus, because it is less expensive than a ride on the traditional rickshaws. The buses are still often stuck in traffic jams, but tests are underway with a new system called Bus Rapid Transit (BRT) with dedicated bus lanes and traffic lights with specific signal technology.

Voith products help to master the technological challenges. The robust DIWA transmission allows smooth acceleration up to a speed range where other transmissions need two, if not three gearshifts. A plus in traveling comfort for the passengers and an advantage for bus operators, because fewer gearshifts mean less wear. The money thus saved can then be invested in more car horns. Or earplugs. //



▷ by modern low-floor versions. These modern vehicles are fitted with illuminated displays, which actually tell the passengers where they are heading. The more expensive models even have air-conditioning and heating systems to make the trip more pleasant during the cold winter and the hot summer months. “The buses are good,” says commuter Lakshmi, a domestic worker. Most people are unable to pay for a daily door-to-door service in an auto-rickshaw. At 30 rupees, the journey costs twice as much as a bus ticket. The people in charge in Delhi have recognized that mobility must not remain a luxury. “The city is at a crossroads,” says traffic expert Santosh Kodukula. Delhi can either go the “American way” and bank on cars. Or it could follow the European model and try to make public transport so attractive that it can compete with the car. “Comfort, ticket prices and traveling times are the crucial le-

vers,” presumes Kodukula. He goes for a two-way strategy. For him, the metro is an investment into the future: “Our children will benefit from it.” On the other hand, the bus network could be expanded much more quickly – in order to avoid more and more people opting for cars or mopeds. He suggests interlinking the metro and the bus network, integrating stops more efficiently and consistently pursuing the model project with dedicated bus lanes. Most Indians are not too bothered by the daily hustle and bustle, due to the population density they are used to. But most of them would certainly welcome a little bit more elbow room in traffic. And then really step on the gas. //

The German journalist Christine Möllhoff lives in the metropolis Delhi and writes from India for several German daily newspapers.

AN INVESTMENT IN THE FUTURE

During the rush hour, the trains are absolutely packed; over 1.8 million passengers use the metro every day.



PHOTO: ISHAN TANKHA

Light relief for the traffic chaos: The metro in Delhi.



Modern, stylish and rather new: The Delhi metro only opened in 2002, but it is one of the most modern systems in Asia.

DELHI'S NEW METRO

ELEGANCE IN SILVER

Gliding swiftly through the metropolis. What is nearly impossible on Delhi's chronically congested roads, the metro can do it – and spreads itself out in the process.

Off to the platform – the metro is due! But things still have to move a little bit more slowly than the fast trains. First of all, there is a security check at the station entrance. A necessity in view of the many people wishing to use the trains from six in the morning to eleven at night. It is also understandable that the city wants to protect the metro and its passengers. Ultra-modern in appearance, the silver trains are among Asia's latest public transport systems. After being opened at the end of 2002, the network now covers more than 180 kilometers. The 138 stations on the six lines are CCTV-monitored and

individually designed. Art students have decorated the walls with paintings – Delhi obviously wants to get its commuters into a good mood. In some of the more rural areas of the metropolitan region, the trains still look like something from a science fiction movie.

But even for Europeans the dimensions of the metro are quite astonishing. The wagons of the Delhi Mass Transit Systems run on a 1 676 millimeter-wide gauge and are therefore also quite uncommonly spacious inside with a width of 3.20 meters. Newly designed lines such as the Airport

Express run on normal gauge. Each train has 240 seats and standing room for another 300 people. The compartments have a constant temperature of 29 degrees Celsius, which is regarded as pleasant in Delhi.

More than 900 final drives, type SE-344 for broad and normal gauge systems, have already been delivered by Voith for the metro cars. Their special design means that the engine does not have to be removed for maintenance work. The Scharfenberg couplers type 330 have also been supplied by Voith. For a safe trip. //

INTERESTING FACTS

Business Region Delhi

2012 is the "Year of Germany" in India. In seven megacities, the Federal Republic will present itself as a partner of the country. The trade volume between India and Germany is to increase from 15 to 20 billion euros in 2012. Germany will also be represented in Delhi, one of India's largest trade locations. The heart of the region's industry beats in Central Delhi. Textiles, electrical and engineering goods are the pillars of the manufacturing industry in the metropolis, which has the third-highest per-capita income in India. But trade is even more important than industrial production. India's capital is a vital platform for banks, and the telecommunications market is also booming. At the same time, traditional areas such as exports of arts and crafts are another essential factor of the business scene in Delhi.

History of Delhi

Delhi was founded by the Pandavas at around 1200 BC. In the middle of the 18th century, the British East India Company arrived at the city and founded a trade post. After 1911, construction of today's New Delhi, a new town built from scratch by architects, began, originally initiated by the English King George V. In 1932, New Delhi was officially inaugurated and is now the seat of the Indian government.

Climate in Delhi

The average annual temperature is 25 degrees Celsius with an average 808 millimeters of rainfall per year.

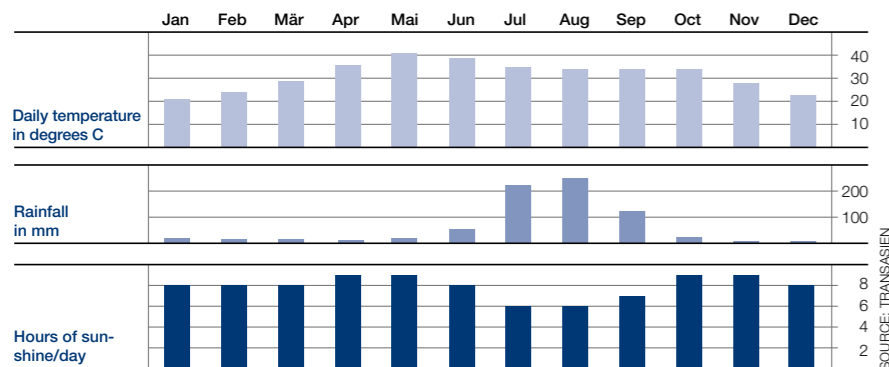

Gross Domestic Product of India

Changes to pre-year quarter in percent



Per-capita income in India

In US dollars, constant prices, on average.

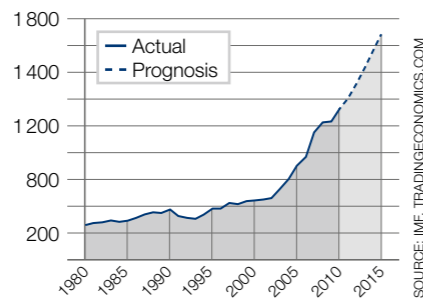

Voith Turbo in India

1968

Installation of the first Voith hydraulic coupling in India. It is still in service. By 2010, another 1800 geared variable-speed couplings were delivered to Indian power stations.

1987

Start of production in Hyderabad, which has been growing continuously ever since. It is centre for manufacturing of hydro-dynamic couplings, retarders and metro couplers. A business with a high potential, because even the smaller cities in India have a population of three to five million – public transport systems are an absolute must.

220

Number of steady employees currently working for Voith Turbo in India. Over the last five years, sales have risen by nearly 400 percent.

Locations of Voith in India

Voith Turbo has a production site in Hyderabad, as well as four regional offices.

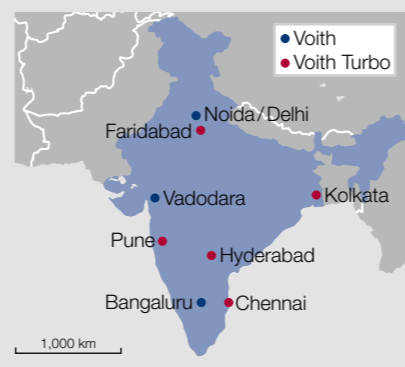

DEBASHIS BASU

The 58-year-old has been Managing Director of Voith Turbo in India since 2008 and is based in Hyderabad.



INTERVIEW

COUNTLESS OPPORTUNITIES

India is one of the largest growth markets. For Debashis Basu, Managing Director of Voith Turbo in India, future success is primarily dependent on increased local production.

Mr. Basu, the Indian economy is growing but the infrastructure can't keep up. Would you regard this as an opportunity for Voith products, for example retarders?

Yes, the Indian automobile sector presents excellent opportunities for Voith products, as road construction is continuously being stepped up. But we must make sure that we are offering the right product at the right time and at the right price.

Why does Voith Turbo have so many good perspectives in India?

We have been enjoying an excellent reputation in India for many years as a company offering high-quality products and services. And Voith Turbo India, which is celebrating its 25th anniversary in 2012, operates at a modern production site in Hyderabad. In view of this strong basis, there will be a high degree of acceptance in the market when new Voith products are being launched. In addition, we will be able to increase our market share even further if we focus even more consistently on our localization strategy. Moreover, Voith Turbo has also signed up a few joint ventures in India.

Is there a Voith product that has been specifically adapted to the Indian market?

Yes, the Voith Retarders VR 119 and 123+. We have already adapted the VR 119 Retarder to the specific Indian requirements and introduced it in the market. The VR 123+ model will follow soon. Further products are

currently under development with the help of our engineering center in Hyderabad.

What is the reputation of "Made in Germany" engineering in India?

For Indian customers there are probably no engineering products that enjoy such a high reputation as those with the label "Made in Germany."

The Delhi Metro runs with final drives and Scharfenberg couplers from Voith. Are there other Voith projects in India with a similar magnitude?

Voith final drives and Scharfenberg couplers have proven themselves in the Delhi Metro. This is why we have received coupler orders for the metro project in Bangalore, as well as orders for couplers and final drives for expansion projects in Delhi. At present we are in discussions with the metro project contracting company M/S BEML regarding couplers and final drives for the metro project in Jaipur.

What is your personal favorite among the Voith products?

It is the geared variable-speed coupling, which is used in the drive-lines of boiler feed water pumps in coal-fired power stations. The first couplings of this type were delivered in 1968, and they still operate trouble-free. The reputation of this product is so good that Voith holds a market share of nearly 100 percent in India. And this type of coupling is also produced in Hyderabad. //



The mega-metropolis Delhi: Combining tradition and modernity.



Things work better together: In the production hall in Hyderabad.

HYDROPOWER FOR INDIA

IN FULL FLOW

Hydropower is an infinite and also reliable source for producing renewable energy. Voith Hydro has been a leading supplier of all associated technologies from the early days of power generation from hydropower.

The first deliveries of Voith turbines to India date back to as early as 1925 – for Talang hydropower station. In 2002, the company established Voith Hydro Private Limited India. The goal: To harness hydropower in India, not least through a stronger local presence.

In 2003, Voith Hydro received an order for equipping one of the country's largest hydropower plants – Omkareshwar. The Voith delivery covered the entire electromechanical equipment of the 520-megawatt power station. The plant was connected to the grid in 2007 – just 48 months after the contract had been signed.

In the German-Indian Year Voith has received further orders from India for the power stations Rongnichu, Sainj and Singoli Bhatwari. Voith delivers turbines and generators, as well as electrical and mechanical components. Expectations in India are high. The clean electricity is meant to help the country to produce much needed energy more and more from its own sources. //

GERMANY AND INDIA 2012

GETTING CLOSER

Germany has been enjoying diplomatic relations with India for 60 years. The event “Germany and India 2011 – 2012” initiated by the federal government specifically for this purpose is headed by the motto “Infinite Opportunities”. Voith is on board.

Angela Merkel paid a special visit. On May 31, 2011, the German Chancellor gave the official opening speech for the project “Germany and India,” which will deepen the friendship between the two countries through numerous events and campaigns and last until January 2013. India and Germany have been enjoying diplomatic relations for 60 years. The Federal Republic will present itself in five cities under the heading “StadtRäume – CitySpaces” as an innovator and sustainable partner. Relevant campaigns are planned for Mumbai, Bangalore, Chennai, New Delhi and Pune. The centerpiece is the Indo-German-Urban Mela, which will travel across the country in the form of a road show with a set of



mobile pavilions. Politically, the countries have already formulated a common goal: Both are in favor of an extension of the United Nations Security Council. Culturally, the ties are also becoming closer: In February 2012, the Indian actor Shah Rukh Khan added a touch of Bollywood to the Berlinale in the German capital with his film “Don – The King Is Back.” The cheers at Khan’s appearance were so ecstatic that even seasoned visitors of the renowned film festival struggled to remember the last time when they had seen such ovations. Things are also on the move on the economic front: In November 2011, the German government agreed to provide India

with a EU 50.5 million subsidy for cooperation and development. Supplemented by funds from the Credit Institute for Reconstruction (KfW), some EU 255 million are thus available for new projects in the field of climate and environmental protection. Voith, too, has a long tradition in India. The company has been active in this market for more than 100 years, and Voith India is celebrating its 25th anniversary this year. Voith actively participates in the German-Indian Year and is a partner of the Indo-German-Urban-Mela in New Delhi. The CitySpaces project deals mainly with the ongoing urbanization in India. Here, products from Voith make a valuable contribution to improving transport infrastructures on roads and rail, and also in the field of energy supplies. For

this reason, Voith will present itself at the road show with its own 75-square-meter pavilion. For Voith, the German-Indian Year is the start of an even closer cooperation in the future. Voith would like to be seen as a modern, forward-looking company. In addition, Voith also strives to make a measurable and, most of all, sustainable contribution to India’s economic development. The company aims to become a socially committed and attractive employer that is deeply rooted in the Indian market.

The perspectives for Voith in India are certainly promising. The country is growing

fast and therefore needs efficient infrastructures. Delhi and Kolkata currently have the most modern urban transport system on rails. Long-distance buses are to be increasingly modernized. And the mining industry, too, is on the up, because the country needs energy for its rapid development. The Voith portfolio covers all of the products needed for these plans. The plant in Hyderabad already produces hydrodynamic couplings. Through the establishment of new contacts, the German-Indian Year can also be a platform for an even more successful future for Voith in India. //

SOURCE: DIRECTORATE GENERAL COMMERCIAL INTELLIGENCE AND STATISTICS

India’s export trade with Germany

in billion US dollars

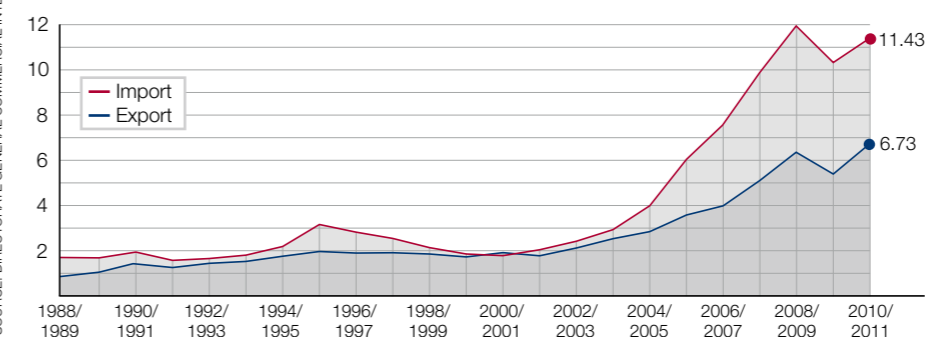



VOITH SCHNEIDER PROPELLER

INGENIOUS TURN

The development of the revolutionary marine drive took a long way – a way on which the inventor Ernst Schneider forgot to finish his engineering studies and eventually oriented himself on an example from nature. The cooperation with Voith enabled his breakthrough.

It was in 1923, when Ernst Schneider started to take a closer look at the development of propellers. Unfortunately, his first idea, a “screw propeller with a bird-wing profile”, did not offer any advantages over existing technologies. Yet anything but discouraged by this early failure, his creative spirits never stopped and, four years later, caused a revolution in marine engineering with the basic patent for the future Voith Schneider Propeller (VSP).

Schneider, born in Gaya, Moravia, on June 18, 1894, studied engineering in Vienna. He was regarded as a determined young man with a perfect grasp of the physical basics, which gave him a solid foundation for his inventions. His most important goal for all his new developments: Genuine practical usefulness.

The initial spark for the invention of the VSP was an article, shown to Schneider in 1925, dealing with the so-called Wels-Propeller

modeled on the movement of fish in water. Schneider recognized the technical shortcomings of this system and was thus motivated to take a further pioneering step. After weeks of intensive work, the new propulsion system was ready.

The inventor was lucky enough to be in close personal contact with the Voith engineer Ludwig Kober. Kober supported Schneider both on the technical and the financial front. Thanks to him, Schneider’s idea was taken up by Voith and, backed by a team of dedicated Voith engineers, successfully launched in the market.

Schneider had initially financed his early attempts by offering private tuition to his fellow students. In the light of his success, his research soon had priority over his studies, and he never finished his degree. Yet in view of

his achievements, he was always addressed as “Chief Engineer.” Starting out as a freelance inventor, Schneider continued to improve the system, which serves as both drive and rudder, in cooperation with Voith: First with engineers from St. Pölten and later also with colleagues from Heidenheim. In 1927, the first Voith-financed test vessel “Torque” was launched and convinced the onlookers because it managed a full turn around its own longitudinal axis in ten seconds.

Today the VSP is in operation in all situations where fast, accurate and efficient maneuver-ability is required, for example for offshore support vessel, tugs, double-ended ferries and many special vessels. To date, 4200 VSPs have been built, and the Voith Schneider Propeller has proven itself in practical applications since 1927. Ernst Schneider died in Vienna on June 1, 1975. //

The inventor (above) and his first, hand-made model (right): Ernst Schneider is the technical father of the Voith Schneider Propeller, which radically transformed marine propulsion systems.



VOITH TURBO

WORLDWIDE



PHOTO: VOLVO

INDUSTRY

- 28 TAMED**
The new power distribution gear can transmit up to 65 megawatts.
- 28 INNOVATIVE**
New development with future prospects: The Voith CLPD linear drive allows quick handling of workpieces.
- 29 CHANGEOVER**
Matthias Grawe has taken over the Business Division Industry. His successor as Head of the Product Group “Variable-Speed Drives” is Martin Kaufmann.

MARINE

- 30 HUGE PROJECT**
For the “Sea Installer” Voith delivers the largest Voith Inline Thruster in the world.
- 31 NEW SIZE**
Voith is expanding its portfolio of Voith Radial Propellers by a second, more compact size.
- 31 WORKER BEE**
The Voith Schneider Propellers for the “Seabed Worker” are driven by 2500-kilowatt motors.

RAIL

- 32 DATA FLOW**
The Web-based tool OPRA is the perfect companion for vehicle fleets.
- 34 ENGINE PACKET**
A newly developed diesel engine turns the Voith drive system Powerpack into a complete solution.
- 35 DIRECTLY ON SITE**
Up to 70 percent of the production of semi-automatic couplers for São Paulo metro takes place directly in Brazil.
- 35 LOCAL PRODUCTION**
China is a huge market for turbo transmissions. Voith produces on site.

ROAD

- 36 LESS RATTLE**
The hydrodamp vibration damper ensures quieter operation for diesel engines – in over one million vehicles.
- 38 MAKING WAY**
Separate bus lines against traffic gridlock: Voith transmissions extend the service life of buses.
- 38 FLAT RATE**
SensoTop reduces fuel consumption – and not only on mountainous routes. Danish buses, too, drive and save with the Voith gearshifting program.

A STRONG INNOVATION

With the development of the CLDP (Closed Loop Differential Pump) linear drive, Voith has entered new territory. The hydraulic linear axis (see photograph) is a completely new development. First prototypes are already in operation in forming and joining processes. End users of the new drive are offered all the advantages of a hydraulic systems development. The design is quite simple. At the heart is an integrated servo pump. The system has a closed oil circuit, can therefore be easily integrated into existing plants and is suitable for applications requiring fast handling of workpieces. //



PRODUCT
Closed loop differential pump

APPLICATIONS
Hydraulic linear axis

TECHNICAL FEATURES
Minimum throttle losses, high energy efficiency due to high hydraulic efficiency, no need for valve technology.



Reliable power transmission.

PRODUCT
Power distribution gear

APPLICATIONS
Especially for power transmission from gas turbines to centrifugal compressors

TECHNICAL FEATURES
Outputs of up to 65 MW, speeds of up to 100000 min⁻¹.

EFFICIENCY OF 98.8 PERCENT

TAMING 65 MEGAWATT

The power distribution gear of Voith Turbo BHS Getriebe has been developed specifically for high power densities and speed ranges.

Reliable power transmission is the be-all and end-all for gearboxes. Voith has been supplying turbo transmissions and high-performance gearboxes in the upper range for 80 years. The new power distribution gear from Voith has been developed primarily for compressors driven by gas turbines – to meet the increasing demand for more efficient gearboxes for high power densities and speed ranges.

A practical example demonstrates how it works: At a gas turbine ratio of 5 000

rotations to the 12 500 rotations of a compressor, the transmission capacity of a planetary gear ends at 26 megawatts. The reason: The circumferential speed at the bearings and the gears cannot be increased any further.

Using the load distribution principle, the new power distribution gear from Voith can transmit up to 65 megawatts in such a speed range. This corresponds roughly to the output of 650 mid-range cars. Even in this borderline application, there is still a 98.8 percent efficiency rating. //

NEW MAN FOR CANADA

Voith Turbo in Canada has a new president. January, 1, Andrew Strudwicke took over at the helm of Voith Turbo in Mississauga, Ontario. From 1993, the 37-year-old graduate engineer and economist studied mechanical engineering at Salford University, UK, followed by a three-year degree in manufacturing engineering and management at Loughborough University in Leicestershire, UK. Andrew Strudwicke began his professional career at the legendary motorcycle manufacturer Triumph Motor Cycles in Hinckley, England. In 1998, the passionate squash and rugby player changed to FKI Industries PLC. Five years later, in 2003, Andrew Strudwicke's career led him to Canada where he worked for the steel-forging company Crosby Canada in Ontario. His final position there was Deputy Executive Vice President. At Voith Turbo Strudwicke succeeds David Calvey. //

ANDREW STRUDWICKE
He is the new president of Voith Turbo in Canada.



MATTHIAS GRAWE
The 51-year-old internationally experienced manager has been in charge of the Business Division Industry since March 2012.

CHANGE AT THE TOP

New man in the executive chair of the Business Division Industry: On March 1, Matthias Grawe succeeded Dr. Jürgen Zeschky as Executive Vice President. The 51-year-old graduate engineer has been working for Voith since 2000. Grawe studied process technology at Stuttgart University and energy management at Grenoble, France. He began his career at Voith in 2000 as Sales Manager "Variable-Speed Drives". In 2003, the married father of a son was appointed as head of the product group. Matthias Grawe has been on the Supervisory Board of Voith subsidiaries from an early stage – in the USA, Canada, Mexico, Brazil, Chile, India, China,



MARTIN KAUFMANN
The new head of the product group "Variable-Speed Drives" has been working for Voith since 2005.

Austria, the Netherlands and Belgium. The internationally experienced manager has also been in charge of Voith Turbo Wind and a member of the Advisory Board of Voith Industrial Services "Energy Petro Chemicals".

Matthias Grawe's successor as head of the product group from April 1 is Martin Kaufmann. The 40-year-old has been working for Voith since 2005. He studied physics at Regensburg University and also Illinois University, USA. After various stations within Voith GmbH and Voith Paper, Martin Kaufmann joined Voith Turbo in Crailsheim in 2009 as Commercial Manager of Industry. //

VOITH INLINE THRUSTER

HALFWAY AROUND THE WORLD

Drive or steering system: Voith Inline Thrusters have made their mark in shipbuilding ever since they entered series production in 2008 – and they are about to set records. The world's largest Voith Inline Thruster is currently installed in China.

Nantong in China, COSCO shipyard, dry docks: Every day, the "Sea Installer" grows a little more in height. The jack-up vessel for the construction of offshore wind plants will be launched in 2012.

It will be operated by the Danish owner A2SEA and help to set up European wind parks. The "Sea Installer" can work in water depths of up to 45 meters, and its main crane can lift 900 tons. The 132-meter-long and nearly 40-meter-wide workhorse will therefore have rather ample dimensions. Voith supplies the three Voith Schneider Propellers (VSP) in the stern of the vessel, as well as the Voith Inline Thruster (VIT). The VIT in question are unique worldwide: Built

by Voith with a diameter of 2 300 millimeters and an output of 1 500 kilowatts, they are the largest RIM Drive thrusters in the market. Thrusters, which work completely maintenance-free thanks to seawater-lubricated bearings, allowing the "Sea Installer" to perform fast and precise steering maneuvers.

Voith Inline Thrusters are so-called RIM Drives. The system combines a permanent magnet motor with the propeller into a powerful unit, which stands out by low noise and low vibration levels. Since reaching series maturity for the product in 2008, Voith has

sold more than 60 of these units. Yet the VIT are also suitable for passenger vessels or yachts – as main drives or as thrusters like in the "Sea Installer".

But before the construction vessel starts its job in 2013, it has to perform its maiden voyage from China to Europe – driven by three Voith Schneider Propellers. //



Voith Dimensions: This film shows impressively how the Voith Inline Thruster is installed in a ship. For more information on how the QR code works, please see page 5.

www.voithturbo.com/applications/qr/vit_installation



A huge project: Employees in front of the Voith Inline Thruster for the "Sea Installer".



Turning the great wheel: A Voith Radial Propeller is being inspected.

CALM IN HEAVY SEAS

Looking for new energy carriers is a labor-intensive business. The exploitation of oil and gas fields or the installation of wind parks requires special vessels with reliable drive and positioning systems. Voith has been gathering relevant experience for more than 30 years on the "Castoro Sei", a semisubmersible platform for laying underwater pipelines. For future projects, Voith is expanding its range of Voith Radial Propellers (VRP) by a second and more compact size. The new VRP has a diameter of 3.80 meters and an output of 4 500 kilowatts. It is mainly used on drilling platforms. Operation is possible in nearly all weather conditions. The larger type with a diameter of 4.20 meters and outputs of up to 5 750 kilowatts has already been produced. //



Practical test: Scan the QR code and see how and where the Voith Radial Propeller is used. For more details on how the QR code works, please see page 5.

www.voithturbo.com/applications/qr/vrp/de

MARITIME WORKER BEE

When a ship's name includes the term "worker," it is pretty clear for which purpose it has been built. The "Seabed Worker" is in worldwide operation for the Norwegian Seabed Group as a supply, repair or inspection vessel. Measuring just under 90 meters in length and 16 meters in width,

the ship offers room for a crew of 66. The stern of the "Seabed Worker" features two Voith Schneider Propellers (VSP) driven by 2 500-kilowatt electric motors. Thanks to the excellent maneuverability of the VSP, the maritime worker bee can operate safely, even if the seas are rough. The ship's solid position on the waters is enhanced by the Voith Roll Stabilization implemented via the propellers. //



Stable position thanks to the VSP: The "Seabed Worker".



A confederate Swiss made by Voith: The locomotives of the Swiss company Panlog are used for steel transports.

MODERN FLEET MANAGEMENT

A DATE WITH DATA

A fast and central computer – fed with information from all over the world – Voith has developed the Web-based tool OPRA for optimum fleet monitoring.

A server is fed online with data from all over the world and processes this input in a user-friendly manner. This is the principle of OPRA, a Voith-developed tool. OPRA stands for “Optimized Pro Active Life Cycle Approach” and is used for Web-based, globally available monitoring of vehicle fleets. This new tool allows effective screening of locomotives or rail wagons across their entire service life. The system is so efficient that availability, reliability and safety are increased, while costs are saved. The basis of the tool is uninterrupted and comprehensive information.

OPRA allows optimum vehicle life-cycle management. An example: A modem in-

stalled in a locomotive transmits all relevant data to a server at Voith. This server then makes this information available to the customer via OPRA. Locomotive owners, who want to know the location of their vehicle, in what condition it is or when the next service is due, can access this and other data wherever there is a network – of course also via smartphone or tablet.

An application example is the rail vehicles of the Swiss transport company Panlog. Three modern Voith locomotives built in 2010 and used for steel transports are fitted with OPRA modems, allowing optimum vehicle care through the OPRA portal.

The energy group RWE is also an OPRA user. The electricity giant has integrated the program into its SAP system and uses it for managing the maintenance of 950 locomotives and rail wagons. OPRA makes service management more efficient, user-friendly and effective. This applies, for example, to data integration, the avoidance of double input and the improvement of data quality. Beyond that, OPRA can also be used for documenting maintenance stops and proving that official regulations have been adhered to. Another OPRA application is weakness analysis. //

OPRA allows monitoring with worldwide availability.



COMPLETE DRIVE SYSTEM FOR POLISH REGIONAL TRAINS

ENGINE PACKAGE

For the first time, Voith delivers complete drive systems for regional trains – complete with diesel engines.



One of three Powerpacks: Railpack with V8 diesel engine.

PRODUCT

Drive system with Voith diesel engine

APPLICATIONS

Rail vehicle drive systems

TECHNICAL FEATURES

The Voith R2876T3-390 R6 diesel engine has a nominal output of 390 kW, a nominal speed of 1 800 min⁻¹ and a displacement of 12.9 l. Operation: 4-stroke diesel with exhaust turbo-charger and SCR system.

Powerpacks are compact units for underfloor installation in railcars, ready to drive the train. They consist of engine, gear unit, cooling system, generator and electronic control. All components are bolted together in a single frame. Worldwide, Voith has sold more than 800 such drive systems.

At the end of this year, four Arriva regional trains will enter service in Szczecin, Poland. They will be built by the Polish rail vehicle manufacturer PESA with a new and unique

feature: For the first time, all components of the Powerpack originate from Voith – including the engine.

The horizontal 6-cylinder Voith diesel engine with an output of 390 kilowatts ensures high displacement and allows maximum speeds of 120 kilometers per hour. Outstanding performance without negative impact on the environment: Voith has ensured that the six-cylinder self-igniter is not only fuel-efficient but also clean. Single-stage turbocharging and

an SCR system effortlessly undercut all current emission limits. The robustness of the engine and the entire drive system are guarantors for reliability, long service life and low operating costs.

Voith offers horizontal six-cylinder engines with outputs of 390, 353 and 294 kilowatts. The catalogue of Voith rail engines also includes a V8 with 500 kilowatts, as well as a V12 series with ratings from 588 to 700 kilowatts. They are suitable for railcars, locomotives and special rail vehicles. //



Voith technology improves infrastructure in São Paulo.

ON SITE – AND ON THE BALL

São Paulo is buzzing. The city is constantly growing and is preparing for a major event: The 2014 Football World Cup. This is why huge sums are being invested in traffic projects. For Line 11 of the rapid transit system of the South American metropolis, Voith will deliver 18 automatic couplers and 63 semi-automatic couplers for a total of nine Alstom trains, each with eight cars. The operator “Companhia Paulista de Trens Metropolitanos” (CPTM) currently operates six lines in the São Paulo region with a route length of 260 kilometers, serving 93 stations. Two further lines are planned and construction is already under way. One of the new lines will connect the international airport with the

city center – an important project, especially in view of the forthcoming Football World Cup. With the order for CPTM, Voith is exploring a new path. More than 70 percent of the semiautomatic couplers are produced directly in São Paulo, ensuring a drastic reduction of the high import taxes. The local solution is also an important step towards the internationalization of Voith’s production capacities in South America. A move that is important for the company’s overall development. Meeting local content requirements on the basis of European quality standards will benefit all parties concerned and constitutes a milestone in know-how transfer and globalization. //

A NICHE FOR TURBO TRANSMISSIONS

China continues to invest in the safety and maintenance of its rail traffic. An opportunity for Voith to establish itself in the growth market of turbo transmissions for special vehicles. Voith has, for instance, localized a rail-grinding train in China with the Swiss company SPENO and the Chinese manufacturer Beijing February 7th Railway Transportation Equipment (BRE). This train will be used for servicing the Chinese high-speed network. Within three years,

65 percent of the L520 turbo transmission was localized at BRE. In order to ensure quality and adherence to time-lines, BRE attended several Voith training courses, all parts are checked in accordance with German standards and a test stand has been set up on site. The core components for the hydrodynamic transmissions are still supplied from Germany. After the first order for 20 turbo transmissions, a follow-on order for another ten was placed in early 2012. //



Rail-grinding trains for the Chinese high-speed network.

VOITH TECHNOLOGY FOR NEW ICX TRAINS

Starting signal for rail traffic of the next generation. From 2016, 300 new long-distance trains of DB German Railways will be successively replacing the old Intercity and Eurocity models. The new ICx will be built by Siemens/Bombardier. Production of the first lot of 130 trains is already under way. Voith will supply 260 front covers with roofs. This delivery includes 260 automatic couplers and 2 000 semiautomatic couplers. The order is one of the largest in the history of Voith Turbo Scharfenberg. The series will run from 2016 until 2020. The ICx will be the backbone of the future long-distance operations of DB German Railways. The next ICx trains will eventually take over about 70 percent of all long-distance traffic of DB. //



A VIBRATION DAMPER FOR ALL

LESS RATTLE

PRODUCT
Hydrodamp vibration damper

APPLICATIONS
Agricultural and construction machinery, off-road vehicles

TECHNICAL FEATURES
Covers engine torques up to 3 700 Nm. Primary-side connection via the flywheel, secondary-side connection via tractor transmissions. Damping is wear-free.

Driving comfort is largely a matter of smooth running. The Voith Hydrodamp removes undesirable vibrations from the driveline. Be it tractors or special vehicles – the Hydrodamp range covers all requirements.

The Voith Hydrodamp torsional vibration damper has been on the market for more than 25 years. And it has proven itself. While vibrations between engine

and transmission are unavoidable, they should be kept as low as possible. The torsionally soft Voith damper is available for agricultural machinery and off-

road vehicles with any engine output. Meanwhile in four sizes.

A concept that has gone down well. At present, approximately 120 000 Hydrodamps leave the production halls in Garching near Munich every year. Tractor manufacturers often have simulations and measurements carried out by Voith during the project phase to ensure that they always select the most suitable damper model. The reduction of torsional vibrations in the driveline enables the driver to save fuel at lower speeds. This cuts down on costs and protects the environment. And, what's more, the Hydrodamp actually increases the driving comfort.

A fact that has also been utilized by the Brit Andy Green. In 2006, the former Royal Air Force pilot set the (still unbroken) speed world record for diesel vehicles on a salt flat in Utah, USA: He managed 563 kilo-

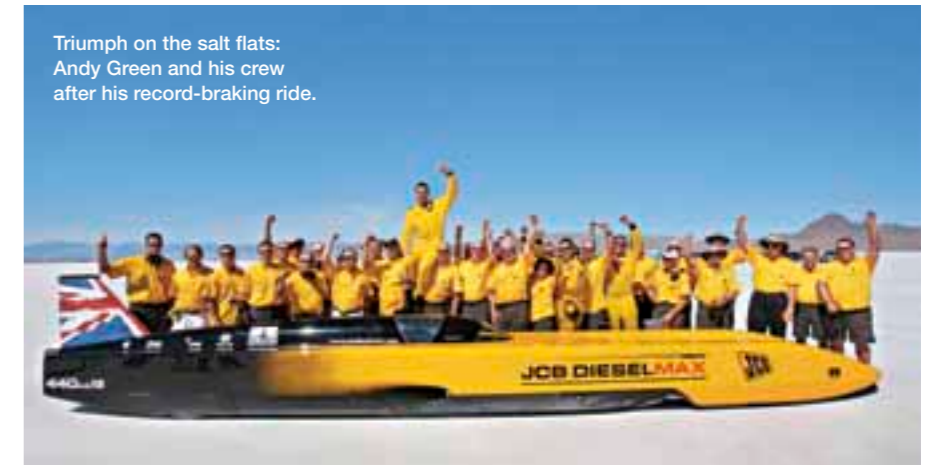

Triumph on the salt flats: Andy Green and his crew after his record-braking ride.

meters per hour. In order to ensure that his cigar-shaped racing car ran more smoothly during this hellish ride, the Hydrodamp was on board.

The Hydrodamp system with its unique hydraulic damping has meanwhile been

developed so far that it has established itself in the market in numerous applications. While sizes and components have remained unchanged, damping effect and spring characteristics can be adapted to individual customer requirements. For less rattle. //



More driving comfort with the Hydrodamp: For example in tractors.



And . . . action:
Scan the code and see the Hydrodamp in action in tractors and commercial vehicles. To learn how the QR-code works, please go to page 5.

www.voithturbo.com/applications/qr/hydrodamp/de

COMBATING GRIDLOCK

MAKING WAY

Separate bus lines create mobility – and with DIWA, Voith delivers the ideal automatic transmission.

Far too many large cities know the problem: Rapid growth means that infrastructures often lag behind the increasing traffic volume. The result: Perma-congestion – with a list of negative effects, such as lower quality of life and rising air pollution. One of the solutions is called BRT (Bus Rapid Transit). In concrete terms: Separate lanes, exclusively reserved for buses. In 2000, the so-called Transmilenio was installed in Bogotá/Colombia. The system still has role

model status worldwide. With the DIWA automatic transmission, Voith delivers the matching technology. In the Colombian capital, Voith has a market share of 84 percent. In total, more than 100 double-articulated Volvo buses are in service. The operators, with whom Voith has been enjoying many years of excellent business partnership, are convinced by the reliability, economy and the local service. And the new buses will also be fitted with DIWA automatics. //



Hop on the bus: in Bogotá, the stops not only have an interesting design – the buses even have their own lane.

PHOTO: VOLVO

SAVING EVEN ON THE FLAT

Denmark is not exactly mountainous. But the Danish company Busselskabet Århus still swears by the SensoTop. Among other services, the operator runs the bus lines in Aarhus.

Busselskabet Århus has ordered the topography-dependent gearshifting program SensoTop for its Solaris buses. SensoTop ensures that the gearshifting points automatically adapt to the load condition of the vehicle, the acceleration and the topography. During test runs on mountainous routes, for example in Brescia, Italy, the system saved up to seven percent fuel.

But the SensoTop has also proven itself in the city of Aarhus. Through optimum adaptation of the gearshifting points, Busselskabet Århus was able to reduce its fuel consumption by 200 000 liters per year. This corresponds to savings of about three percent, which also benefit the environment by lower CO₂ emissions. A win-win situation – thanks to SensoTop. //

VOITH AQUATARDER SWR – BRAKING SYSTEM WITH A FUTURE

TEST RIDE

Railways are the key inspiration. In the beginning, retarders were used for braking heavy goods trains. Some 40 years ago, the system was introduced on the roads, marking the start of a success story. Voith took a quantum leap with the development of the Voith Aquatarder SWR with 700 hp continuous braking power.

TEXT: JÜRGEN LÖHLE

Safety on the roads:
The new Mercedes-Benz Actros drives with the Voith Aquatarder SWR.



CHANGE AT THE TOP IN ANKARA

Since March 1, 2012, Cem Binici has been the new Executive Vice President of Voith Turbo in Turkey. The 38-year-old studied engineering sciences in Ankara (BSc) and then gained a Master's degree in Business Administration (MBA). Cem Binici has so far mainly worked in management

positions in the automobile industry. After posts at Ford, Mercedes-Benz and Mazda in Turkey, as well as at a business consultancy in Germany, Binici moved on to join Voith. And now the passionate swimmer and bridge player has returned to his old university city Ankara. //



A clean brake: Retarder technology reduces brake dust emissions by up to 80 percent.



DR. TILMAN HUTH

The graduate engineer heads the Engineering Department of the Business Unit Driveline at Voith in Crailsheim.



They'll always go down. The only question is: How? This does not only apply to planes but also to trains. This is why the birthplace of the modern retarder was not so much on the road but in the Rocky Mountains – on a railway system.

During the fifties, the USA experienced an upswing, the economy was growing rapidly and needed steel. Huge goods trains, fully laden with iron ore, rolled through the mountains. Monsters with a length of up to five kilometers struggled uphill to reach the furnaces of the steel mills. But the problem was not so much the power needed to pull the trains across the mountains, despite their cargo of up to 10 000 tons. In the land of unlimited opportunities, the operators just increased the number of locomotives in front of the wagons to reach the desired output.

But there is still no such thing as a land of unbraked opportunities. And definitely not on the rail tracks in the Rockies with gradients of up to 30 per thousand. Conventional brakes were no longer able to provide the required retardation. They just got too hot, once the load became too heavy and the downhill route became too steep. At the time, Voith received an order to develop a hydrodynamic brake. In 1959 engineers designed a clutch brake for locomotives that acted upon the drive – the precursor of today's successful Voith Aquataraders SWR.

“Later on we were the first to offer a retarder for road vehicles,” says Dr. Tilman Huth, Head of Engineering of the Business Unit Driveline at Voith in Crailsheim. Today the company produces more than 60 000 retarders per year and delivers to renowned OEMs all over the world. But it was a long way

ALL WATER OR WHAT?

With the change from oil to water as the retarder medium, Voith managed a technological quantum leap.

until then, paved with numerous technical innovations and patents. After the braking system for trains, it took until 1968 before the retarder had its debut in road vehicles. And the incentive once again came from the rails. In early 1960, Otto Kässbohrer stood at Ulm railway station, waiting for the fast train from Stuttgart. As always, the Ulm-based entrepreneur and manufacturer of Setra coaches expected the train to arrive with ear-splitting, metallic screeching noises and spark-emitting brake shoes. But the train hardly made a sound and came to a halt after a surprisingly short distance. Kässbohrer was amazed and the curiosity of the Swabian vehicle builder was awakened. Always on the go, he inquired about the braking system. Afterwards he went to Voith in Heidenheim and asked whether this braking principle could be transferred to his coaches. Kässbohrer was aware of the shortcomings of traditional friction brakes for wheels: Temperatures of more than 1000 degrees and quickly-wearing linings in the drums. Voith took up the idea and began a long and successful venture. In 1968, the first coaches with the Voith Retarder B 180/B 190 entered service. By 1994, the 100 000th retarder had been delivered. In 2002, Voith finally took the quantum leap. Until then, retarder technologies relied on oil as the operating medium. At the IAA in Hannover, Voith presented the Voith Aquatarader PWR (Primary Water Retarder, installed at the engine front end) which operated with the engine coolant. “The innovative aspect was that we were able to utilize a medium that was already available via the cooling system,” explains Tilman Huth. A step that needed careful consideration. “Water has its problems,” says Huth. But it also offers advantages: A modern Voith Aquatarader SWR, like the one used in the new Mercedes-Benz Actros, has a braking output ▷

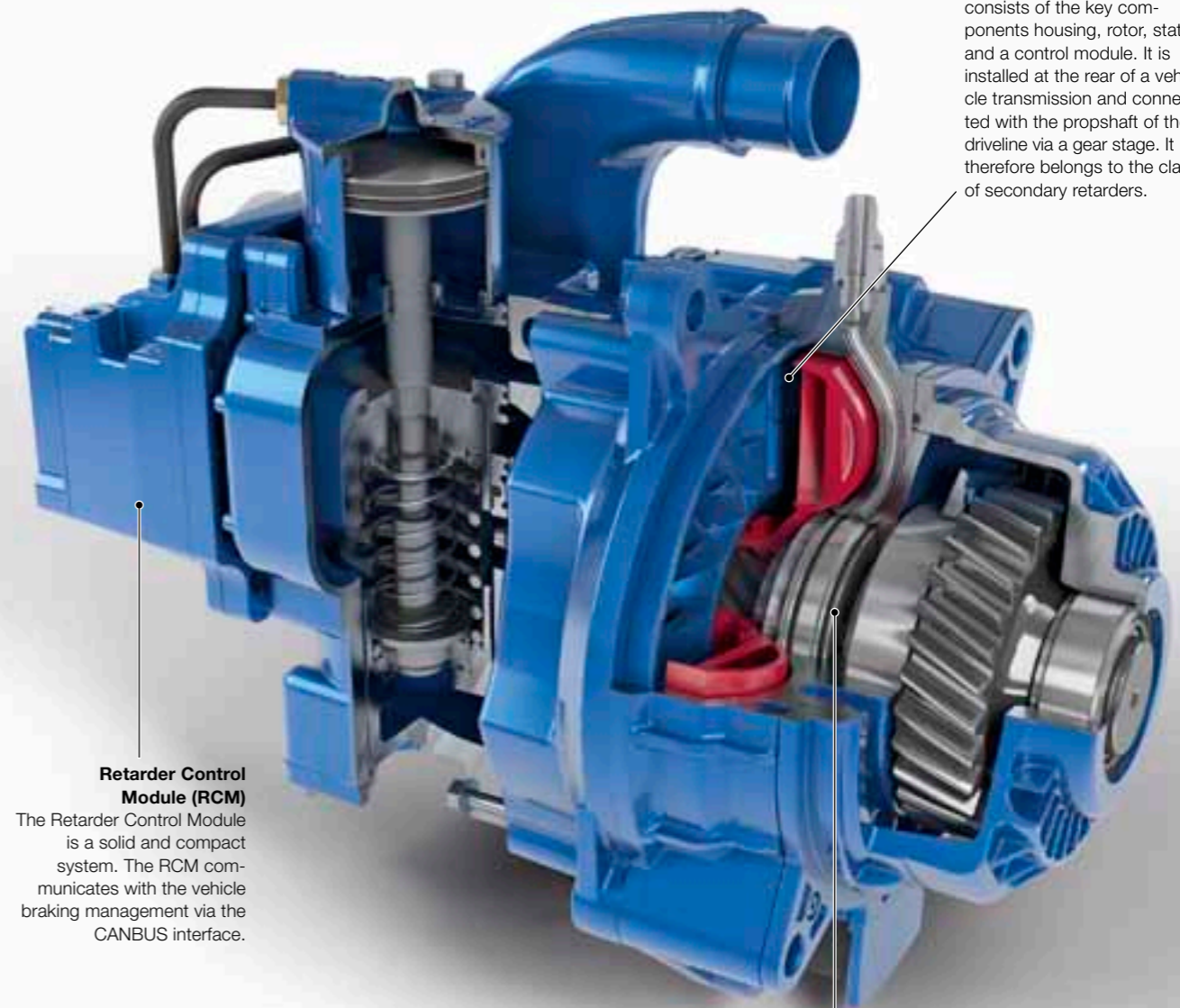

Retarder Control Module (RCM)

The Retarder Control Module is a solid and compact system. The RCM communicates with the vehicle braking management via the CANBUS interface.

Voith Aquatarader SWR

The hydrodynamic retarder consists of the key components housing, rotor, stator and a control module. It is installed at the rear of a vehicle transmission and connected with the propshaft of the driveline via a gear stage. It therefore belongs to the class of secondary retarders.

Rotor shift

After each braking process, the retarder circuit is drained and a spring moves the rotor back into idling position via a helical gear. The rotor shift – away from the stator – reduces power losses during idling.

What is a retarder?

The word “Retarder” originates from the Latin verb “retardare”, which translates as slowing down or stopping. The subject is therefore a brake, but a very special one. While the brakes of road vehicles normally act straight on the wheels, the retarder, as a wear-free continuous brake, slows down the propshaft. Retarders are differentiated by the part of the drive which they affect. Primary retarders are arranged

before clutch and transmission and therefore brake the engine. Secondary retarders act on the propshaft behind the transmission. In simple terms, a retarder works like this: Inside the retarder are two bladed wheels – rotor and stator. The rotor is driven by the propshaft and accelerates the operating medium. Which is then decelerated in the stator. The rigid stator brakes the rotor and thus the vehicle.



Effective technology: With the Voith Aquatarder, a truck on a long-distance route needs to use the service brake 70 percent less than a vehicle without it.

▷ of 700 hp. Together with the engine brake, as much as 1 200 hp is available. Compared to an oil retarder, the system is 35 kilograms lighter and saves six liters of oil per year. And there is no need for maintenance or waste oil disposal. But the environment benefits most: The retarder technology reduces brake dust emissions by up to 80 percent. This corresponds to 50 kilograms of brake abrasion per one million kilometers.

Impressive figures – for which the Voith Aquatarder SWR was awarded the “European Transport Sustainability Prize 2012” in the commercial vehicle components category.

CLEAN AND AFFORDABLE SOLUTION

Driving with foresight and with a retarder saves fuel and CO₂ emissions.

The jury lauds companies that combine economic success with exemplary social responsibility and ecological commitment. “To us, this was both an honor and an affirmation,” says Tilman Huth.

But the retarder proves its strength not only in terms of eco-benefits. The system also offers convincing commercial advantages. With brake faster to your destination: This might sound slightly crazy, but it hits the spot. Example – long-haul traffic: During a test in long-distance goods traffic from Italy to Germany over 3 200 kilometers, a heavy truck with a Voith Retarder needed

the service brake 70 percent less than a truck without retarder. This was added to by a third fewer gearshifts and nearly six percent higher average speeds. Retarders make driving not only safer and faster, but also less expensive.

The calculation quickly works out. At a purchasing price of about EUR 4 000, the retarder usually pays for itself after two years. The conquest of the wear-free continuous brake is seemingly unstoppable – the advantages are too irresistible. Therefore, truck and coach manufacturers cooperate directly with Voith. During the planning stage for the new Mercedes-Benz Actros, for example, the company was involved right from the start. The Aquatarder is usually installed directly at the transmission and only needs half the space of previous models. The future therefore lies in taking the retarder into account already during the vehicle development. If plans have progressed too far and are too cast-

iron, subsequent retarder installation is still not impossible, but a little more complicated.

The Voith experts are already working on the further optimization of the Aquatarder SWR. “Systems integration will be even better, and the unit will be even more efficient and lighter,” says Tilman Huth, yet he has to admit that the conversion from oil to water constituted a quantum leap that is not likely to be repeated anytime soon. “I think that with the development of the Aquatarder SWR we have marketed a technology that will definitely assert itself.” //



Live test ride: Scan the code and see how Voith Retarders are tested in practice. To learn how the QR code works, please go to page 5.

www.voithturbo.com/applications/qr/voith_retarder/

The Voith Aquatarder SWR in the drive system

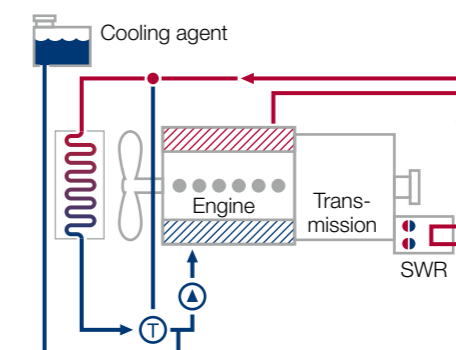

The Voith Aquatarder SWR is a so-called secondary water retarder. It is installed at the transmission and integrated into the cooling circuit (see graph). The SWR uses the cooling agent of the engine as operating medium and is lighter than an oil retarder. In the new Mercedes-Benz Actros, 35 kilograms are thus saved. During braking, the Aquatarder supports the water pump of the engine. Heat generated in this process can be utilized for heating and keeps the engine at an optimum operating temperature during coasting, making sure that CO₂ emissions are kept within prescribed limits.

Driving faster and simultaneously protecting the brake linings

The test: On a route with a total length of 3 164 kilometers between Italy and Germany, a heavy truck comes into its own in customer operation. The result: In long-distance traffic, too, the Voith Retarder once again proves itself through 70 percent less foot brake action, 36 percent fewer gearshifts and 5.9 percent increased average speeds.

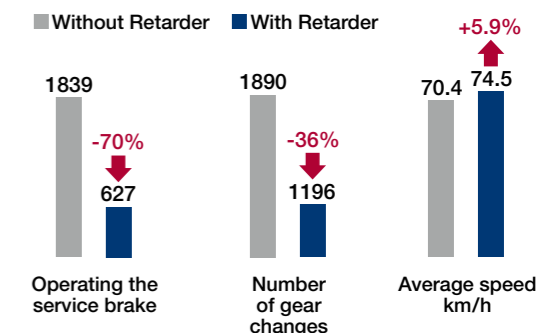

Higher braking outputs with Voith Aquatarder SWR and engine brake

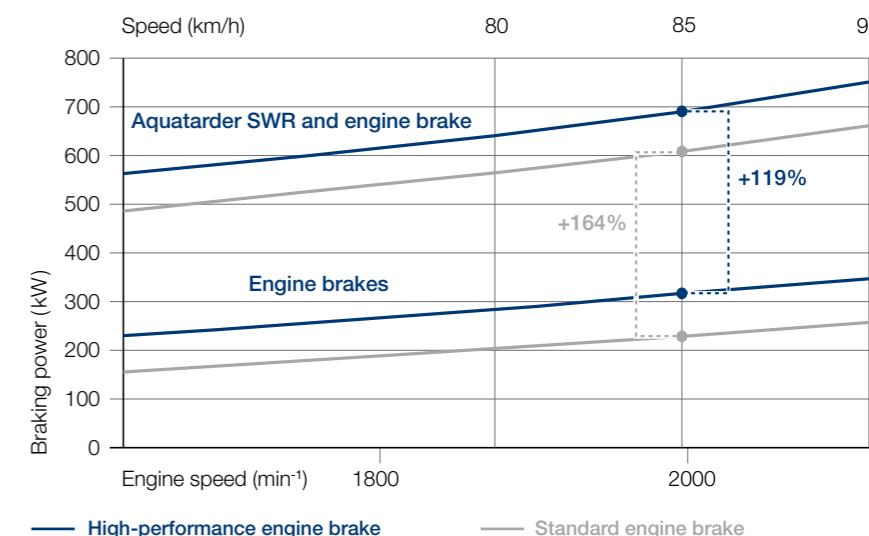



The expert:
Holger Günther appreciates the practical benefits of Voith Retarders.

INTERVIEW

“FASTER ON THE ROAD”

Holger Günther works in the Voith Retarder Sales Department. He frequently drives large trucks and appreciates the advantages offered by a retarder.

Mr. Günther, what was it like to drive a heavy truck before the retarder was developed?

Totally different. The rule of thumb used to be: The speed downhill is the same speed managed by the vehicle during the previous uphill stretch. Which means: If a fully loaded truck did 40 kilometers per hour on an upward gradient, the speed downhill was no faster with service and engine braking – in fact often less. Quite a few drivers remember the warning signs, for example on the Aichelberg stretch along the A8

autobahn between Munich and Stuttgart, which prompted them to shift back into second gear. Consequently they crawled down the valley at 20 or 30 kilometers per hour, frequently with red-hot braking discs.

Sounds dangerous?

Over prolonged periods, friction brakes can reach temperatures of up to 1000 degrees Celsius. By then, the braking power has rapidly dropped, there might be cracks and the brake linings wear down. Continuous brakes such as hydrodynamic retarders

offer enormous safety reserves and shorten the braking distance. Today, retarders are mandatory in coaches, and 90 percent of all long-distance trucks drive with a retarder on board.

I see – trucks have a range of braking systems. How does this work?

In a modern heavy truck, the driver routinely uses the foot brake. The rest is done via a control unit. This means: The on-board computer selects the brake that handles the prevailing situation most efficiently. The wheels are braked only if the slow-down effect of the retarder and the engine brake is no longer sufficient. But the retarder can also be activated manually via a hand lever.

What is the practical difference between slowing down the vehicle with the retarder instead of simply braking the wheels?

For buses in city traffic, the difference is striking. Standard wheel-braking causes the vehicle to tilt. This means the bus is slightly moving forwards. Passengers can feel this, especially if the bus constantly starts and then brakes again. In contrast, the retarder brakes the propshaft at the rear. This means that the bus stays horizontal – which is a lot more pleasant for the passengers, especially those who are standing. In trucks, it is an advantage particularly during animal transports.

Does a retarder also offer more safety?

Yes. Engine outputs are getting higher and higher, but engine brake capacities have remained unchanged. Long downhill gradients can therefore produce overheated discs and linings, which can result in fading. Fading means a dangerous drop in braking power due to the heat development on the brake linings and discs. But with a retarder, a long-distance trucker can perform up to 90 percent of all braking operations without using any other system. The service brake is thus 100 percent available if serious braking is required, and the braking distance is

correspondingly shorter. The same applies to stopping. The retarder alone cannot do this, because it only slows down the drive shaft but never halts it completely.

But retarders are still an optional extra – they are not standard equipment. What does the pro say?

It's quite simple – once with a retarder, always with a retarder. I'm absolutely sure about this. In long-distance traffic, in the 40-ton range, there is hardly any vehicle without it. And the advantages of the retarder are obvious. Due to the fact that the driver can go faster on downhill routes, he also arrives earlier – and, at the same time, travels much more safely. And the environment is also protected, because there is less brake dust. This saves extra money. The installation of a retarder therefore definitely pays off.

But first of all, you have to pay. A retarder costs about EUR 4000.

That's right, but when you consider that – without a retarder – the brake linings and discs have to be changed up to five times more often, this outlay quickly pays for itself. With a retarder, brake discs last for up to a million kilometers. Also, Aquatarders do not require any maintenance. There are model calculations which demonstrate that the investment in a retarder pays off after one to two years. But modern trucks run a lot longer than that. Which means that a retarder actually helps to save money in the long run. //





Precise technology made in Brazil: An employee of Voith Turbo working at a DIWA transmission.

VOITH TURBO IN SÃO PAULO

GERMAN HOT SPOT WITH POTENTIAL

São Paulo is the largest city on the southern hemisphere – and a huge industrial location, especially for German companies. Ralf Dreckmann, Executive Vice President of Voith Turbo in Brazil, talks about living and working in a megacity in the subtropics.

Ralf Dreckmann ponders for a few seconds. “Well, it’s really fifty-fifty” is his reply to the question whether he feels more like a German or a Brazilian. The mechanical engineer has been living in São Paulo for over 20 years. He arrived in South America with his parents when he was still at school, and after his high school graduation returned to Germany to go to university. Upon completion of his degree, Dreckmann went back to São Paulo, where he has been working as a Voith Turbo Executive Vice President since 2000. Two years ago, the 44-year-old was also appointed Regional Director for South America.

Lots of work in a city that is hot in every respect. What is regarded as a somewhat chilly summer in Germany, counts as deepest winter in the largest industrial location of the world’s emerging markets. With just under 20 degrees Celsius during the day, temperatures are at their lowest in the subtropics. Once, in June 1918, there was even snow. A hot event is the annual Formula One race in Ayrton Senna’s hometown. But what really brings the place to boiling point – with nearly 20 million inhabitants the largest city in the southern hemisphere – is its industry. And especially when it comes from Alemanha. “After Germany, São

Paulo is the second-largest community of German companies,” explains Dreckmann. “More than 2 000 German companies have meanwhile settled here.” A German hot spot in the southern hemisphere. “And it also makes for easy living,” says Dreckmann who is married to a Brazilian. Their two children go to the same school that he once attended. Sometimes, Dreckmann would like to see a little less chaos in the streets, “but then again, we live in a city with countless attractions and interesting leisure time opportunities.” This also has an impact on the local industry. Voith holds a particularly strong position with the sales of DIWA automatics for the ever more popular bus traffic in South America. In addition, every year, more than 5 000 retarders are being sold. And the market opportunities are on the increase. For the Football World Cup in 2014 and the Olympic Games in Rio in 2016, the country plans to invest about 27 billion euros in its public transport systems. A traditional market for Voith. “We are already working flat out with our Road and Rail sales teams in order to fully exploit this potential,” says Dreckmann. The metro in São Paulo with its 75-kilometer network relies on Scharfenberg couplers. Three million peo- ▷

RALF DRECKMANN has been Executive Vice President of Voith Turbo in Brazil since 2000. The 44-year-old engineer has been living in São Paulo for more than 20 years.



▷ ple use the system every day. Two new lines are currently under construction. Every year, eight kilometers of new routes are to be built. For the extraction of iron ore, various Voith mining couplings are used. Technology made in Germany can also be found in other places in South America. An example: The train taking tourists in the Peruvian Andes on the traces of the Maya across spectacular ramps to the ancient ruins of Machu Picchu situated at an altitude of 2 400 meters. The locomotive of the train drives with a hydraulic transmission from Voith.

Ralf Dreckmann has his eye on the future of Voith. New gas fields have been discovered 250 kilometers off the Brazilian coast at a depth of 7 000 meters. During the preparatory phase, Voith will deliver 60 Vorecon gears for the compressor drivelines of the offshore oil platforms. For this purpose, a special assembly and test plant is to be built by 2014. Voith technology will also be used for the drilling vessels. The intention is to have the Voith Radial Propellers for the drill-

ing vessels exploiting the new oil fields produced at Voith in Brazil. The future therefore has lots of work in store for Dreckmann who, together with his family, lives in a city that enjoys the title “International Capital of Gastronomy” alongside Paris, New York and Tokyo. Another thing he really appreciates is the friendliness of the Brazilians. “Wherever you are, you are always welcome.” Welcome and professionally respected. German engineering is rated highly in South America. But Ralf Dreckmann has also observed that many domestic engineers are meanwhile masters of their trade. This development is promoted by the long-standing relationships between German and Brazilian companies. With positive consequences for the country. “At Voith in Brazil, nearly all key positions are held by Brazilians,” states Dreckmann. In addition, the company is also socially committed. Since 2004, Voith looks after the social and cultural integration of young people living near the Voith headquarters in the district of Jaraguá. Since 2007, 120 children play every year in a Voith-sponsored classical orchestra. “Every



São Paulo has nearly 20 million inhabitants – and the megacity keeps growing and growing.

year, we also offer opportunities for at least 20 particularly underprivileged children from the Voith environment to integrate themselves socially and professionally via concrete training programs,” says Dreckmann – once again demonstrating that he is German and Brazilian in equal measures. //



A bit of fun for the little ones: The Voith Foundation has been established to help disadvantaged children in São Paulo.

WORTH KNOWING

SUCCESS FIGURES

With its four divisions, Voith offers a broad spectrum of products and services – all around the globe. The overriding goal for all divisions is to operate ecologically and responsibly.

5 9 6 5

... people worked for Voith Turbo at the 2010/2011 reporting day. About ten percent more than in the previous year. And there were more than enough exciting tasks for the growing workforce: Engineers have, for example, developed an innovative propulsion system for ships. This time, the Voith Schneider Propellers are not only installed in the bow area, but also below bow and stern. Supertankers and luxury cruisers can thus be steered safely also in narrow canals and sea straits. Experts have proven it in the Heidenheim test tank: These sea giants can be maneuvered with centimeter precision. In total, Voith has about 40 000 employees in more than 50 countries. //

30

... percent less fresh water is used by the Swiss paper mill Perlen Papier AG. The reason behind this is a consistent water management system from Voith Paper. It covers all areas from waste-paper processing and the two paper machines to the water treatment plant. This is not only good for the environment but also commercially advantageous for the paper maker. //

13.9

... gigawatt hours of electricity will be produced every year by the new hydropower station in Xiluodu, China, when it enters service in 2013. In summer 2011, Voith Hydro delivered the first turbine runner for the mega project, which will become the third most powerful hydropower plant in the world. And the dimensions are gigantic, too: In the 400-meter-deep gorge, even Germany’s highest building, the 368-meter Berlin television tower, would completely disappear. Voith will install three 770-mega-watt Francis units for Xiloudu from its plant in Shanghai. //

150

... members counts the team provided by Voith to take on the facility management of a Ford plant in São Paulo. Voith Industrial Services also looks after the paint shop of KIA in Slovakia and handles the maintenance for BMW in Leipzig. //

3

... core areas were identified by Voith for reducing the eco-footprint of the company: Carbon dioxide emissions, waste volume and fresh water use. The management has defined concrete, sales-based targets. If possible, ecological measures should also create added economic value. Voith is, for example, pursuing the idea of a plant that covers its own energy requirements and continually reuses resources. In order to move closer to this goal, employees analyze the manufacturing processes of products and services under the aspect of sustainability. In 2011, Voith published its first Sustainability Report. The second one is to follow this year. //